

**CC/M/EXAM.
2020**

CIVIL ENGINEERING

PAPER—I

Time : 3 hours]

[Full Marks : 250

Note : Question Nos. 1 and 5 are compulsory and out of the remaining, any **three** are to be attempted choosing at least ONE question from each Section. The number of marks carried by a question/part is indicated against it.

SECTION—A

1. Answer *any five* of the following questions :

10×5=50

- (a) A solid circular rod that is 600 mm long and 20 mm in diameter is subjected to an axial tensile force of $P = 50$ kN. The elongation of the rod is 1.40 mm, and its diameter becomes 19.8 mm. Determine the modulus of elasticity and the modulus of rigidity of the material. Assume that the material does not yield.
- (b) Explain the dependence of span/effective depth ratios (for deflection control, as per Code IS 456 : 2000) on the percentage of tension and compression reinforcement, as well as the grade of tension steel.
- (c) Find the moment of inertia about the centroidal axis XX and YY of the angle section 100 mm × 80 mm × 20 mm with 100 mm as the base.
- (d) A timber beam of 3 m span carries a uniformly distributed load of 5000 N/m and a point load of 1000 N at the centre of the span. If the permissible stress be 100 N/mm², find the section taking depth as twice the breadth.
- (e) A uniform crate shown in the figure given below has a mass of 20 kg. If a force $P = 80$ N is applied to the crate, determine if it remains in equilibrium. The coefficient of static friction is 0.3.

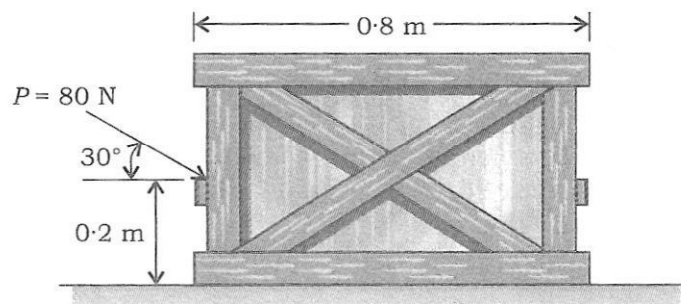

- (f) A solid shaft is to transmit a torque of 20 kNm. If the maximum shear stress induced in the shaft is not to exceed 100 N/mm^2 , find the minimum diameter of the shaft.
- (g) A beam of rectangular section is simply supported at ends and carries a concentrated load at midspan. The maximum longitudinal stress = 12 N/mm^2 and the maximum shear stress = 1 N/mm^2 . Find the ratio of the span to the depth of the beam.

2. Answer the following questions :

- (a) Determine the various stresses set up at midspan in a pretensioned beam $250 \text{ mm} \times 500 \text{ mm}$, subjected to an initial prestress of 1500 kN and uniformly distributed superimposed load of 5 kN/m over a span of 15 m. Assume total loss of prestress as 12% and eccentricity of prestress at midspan is 100 mm. 20
- (b) A three-hinged parabolic arch hinged at the supports and at the crown has a span of 24 m and a central rise of 4 m. It carries a concentrated load of 50 kN at 18 m from left support and a uniformly distributed load of 30 kN/m over the left portion till the mid-section. Evaluate the bending moment and radial shear at a section 6 m from the left support. 15
- (c) Using limit state method, design an RCC short column of size $400 \text{ mm} \times 500 \text{ mm}$ carrying a factored axial load of 3000 kN. Assume $e_{\min} < 0.05 D$ and M 25 concrete and Fc 415 steel. 15

3. Answer the following questions :

- (a) Using Castigliano's theorem, determine the vertical deflection at the free end C and rotation at A. Assume EI constant. 20

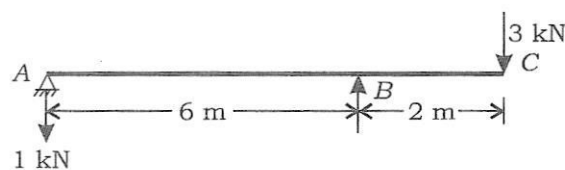

- (b) Four-point loads 8 kN, 15 kN, 15 kN and 10 kN have centre to centre spacing of 2 m between consecutive loads and they cross a girder of 30 m span from left to the right with 10 kN load leading. Calculate the maximum bending moment and shear force at 8 m from the left support. 15
- (c) A cantilever beam AB of length 6 m is fixed at A and free at B. The beam is loaded with two concentrated loads of 40 kN and 60 kN at 2 m and 4 m respectively from the end A. If a rigid support is placed at 10 mm below the free end, analyse the reactions at the fixed support A. Take $EI = 150000 \text{ kNm}^2$. 15

4. Answer the following questions :

- (a) A simply supported beam with an overhang carries a point load of 5 kN at the free end of the overhang. Determine the reactions at the support using stiffness matrix method. Consider the beam to be ABC with length of $AB = 2$ m and BC (overhanging portion) = 2 m. Support at A is a hinge and at B is a roller. Take EI to be constant.

20

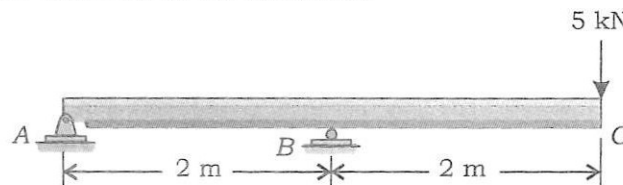

- (b) Determine the vertical displacement of joint D . Assume the members are pin-connected at their ends and EI is constant.

15

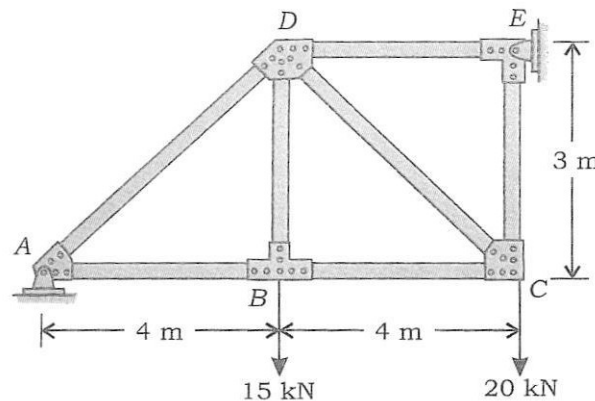

- (c) A simply supported beam of 6 m length carries a vertical load of 1 kN at a distance 4 m from left-hand support. A couple of 2 kNm acting clockwise at a distance of 2 m from the left-hand support. Draw the bending moment and shear force diagram.

15

SECTION—B

5. Answer **any five** of the following questions :

10×5=50

- (a) A cylindrical tank 0.9 m in diameter and 2 m high, open at the top is filled with water to a depth of 1.5 m. It is rotated at its vertical axis at N r.p.m. Determine the speed of rotation in r.p.m. which will raise the water level even with the brim.

- (b) For a two-dimensional potential flow, the velocity potential is given by

$$\phi = 4x(3y - 4)$$

Determine the velocity at point (2, 3). Determine also the stream function and its value at a point (2, 3).

- (c) A model of spillway is made to test the flow. The discharge and the velocity of flow over the model were measured as $2.5 \text{ m}^3/\text{s}$ and 1.5 m/s respectively. Find the discharge and the velocity over the prototype which is 50 times larger than its model.

- (d) Determine the loss of head and the pressure drop when air at 1.01 kN/m^2 and 20°C flows through a smooth rectangular duct of $45 \text{ cm} \times 30 \text{ cm}$ cross-section and 600 m long with a mean velocity of 4 m/s . Take $\nu = 1.5 \times 10^{-5} \text{ m}^2/\text{s}$ and $\gamma = 12.1 \text{ N/m}^3$, air at 20°C .
- (e) Define allowable bearing pressure. Discuss in detail the settlement of shallow foundations.
- (f) A retaining wall 6 m high, with a smooth vertical back is pushed against a soil mass having $c' = 45 \text{ kN/m}^2$ and $\phi' = 15^\circ$ and $\gamma = 19 \text{ kN/m}^3$. What is the total Rankine passive pressure, if the horizontal soil surface carries a uniform load of 50 kN/m^2 ?
- (g) Explain the various factors that affect the compaction.

6. Answer the following questions :

- (a) (i) Depending upon the direction of flow within the runner with respect to the turbine axis, reaction turbines can be divided into how many types? Explain in detail.
- (ii) In a vertical shaft inward flow reaction turbine, the sum of the pressure and kinetic heads at entrance to the spiral casing is 120 m and the vertical distance between this section and the tail race level is 3 m . The peripheral velocity of the runner at entry is 30 m/sec , the radial component of velocity of water (velocity of flow) is constant at 10 m/sec and the discharge from the runner is without whirl, i.e. radial discharge. The hydraulic losses are—
- between turbine entrance and discharge from guide vanes, 4.5 m ;
 - in the runner, 8 m ;
 - in the draft tube, 0.8 m ;
 - kinetic energy rejected in the tail race, 0.5 m .

Determine—

- (1) the guide vane angle and the runner blade angle at inlet;
- (2) the pressure heads at entry to the runner and discharge from the runner.

- (b) An oil having a viscosity of 0.096 Ns/m^2 and a specific gravity of 1.59 flows through a horizontal pipe of 5 cm diameter with a pressure drop of 5.89 kN/m^2 per meter length of the pipe. Determine—
- (i) rate of flow in kg/min ;
 - (ii) the shear stress at the pipe wall;
 - (iii) the total drag for 100 m length of pipe;
 - (iv) the power required for 100 m length of the pipe to maintain the flow.

- (c) For steady Poiseuille flow in a pipe of radius R , obtain expression for δ^*/θ .

7. Answer the following questions :

- (a) The angle of a reducing bend is 60° (that is deviation from initial direction to final direction). Its initial diameter is 30 cm and final diameter is 15 cm and is fitted in a pipeline, carrying a discharge of 360 L/sec. The pressure at the commencement of the bend is 2943 bar. The friction loss in the pipe bend may be assumed as 10% of the kinetic energy at exit of the bend. Determine the force exerted by the reducing bend. 20
- (b) Discuss the various methods of estimating pile load capacity. 15
- (c) An unconfined compression test was conducted on an undisturbed sample of clay. The sample had a diameter of 37.5 mm and was 80 mm long. The load at failure measured by the proving ring was 28 N and the axial deformation of the sample at failure was 13 mm. Determine the unconfined compressive strength and the undrained shear strength of the clay. 15

8. Answer the following questions :

- (a) (i) Write down the step by step procedure for classification of soil as per Indian Standard. 20
- (ii) List the different types of clay minerals along with their structural formula. Describe the structure of the clay minerals with schematic diagram.
- (b) The following data refers to a compaction test as per Indian Standard (Light compaction) :

Water content (%)	8.5	12.2	13.75	15.5	18.2	20.2
Weight of wet sample (kg)	1.80	1.94	2.00	2.05	2.03	1.98

- (i) If the specific gravity of soil grains was 2.7, then plot the compaction curve and obtain the maximum dry unit weight and the optimum moisture content.
- (ii) If the specific gravity of soil grains was 2.7, then plot the 95% and 100% saturation lines.
- (iii) If it is proposed to secure a relative compaction of 95% in the field, what is the range of water content that can be allowed?
- (iv) Would 20% air voids curve be the same as the 80% saturation curve? 15
- (c) What is mechanical stabilization of soil? Discuss the various methods of mechanical stabilization of soil. 15
