

DO NOT OPEN THIS TEST BOOKLET UNTIL YOU ARE TOLD TO DO SO

T.B.C. : PKL-D-ETE

Test Booklet Series

Serial No.

1024413

TEST BOOKLET

A

PAPER—II

( Electrical Engineering )

Time Allowed : Three Hours

Maximum Marks : 300

INSTRUCTIONS

1. IMMEDIATELY AFTER THE COMMENCEMENT OF THE EXAMINATION, YOU SHOULD CHECK THAT THIS TEST BOOKLET DOES NOT HAVE ANY UNPRINTED OR TORN OR MISSING PAGES OR ITEMS, ETC. IF SO, GET IT REPLACED BY A COMPLETE TEST BOOKLET.
2. Please note that it is the candidate's responsibility to encode and fill in the Roll Number and Test Booklet Series A, B, C or D carefully and without any omission or discrepancy at the appropriate places in the OMR Answer Sheet. Any omission/discrepancy will render the Answer Sheet liable for rejection.
3. You have to enter your Roll Number on the Test Booklet in the Box provided alongside. DO NOT write anything else on the Test Booklet.
4. This Test Booklet contains 150 items (questions). Each item comprises four responses (answers). You will select the response which you want to mark on the Answer Sheet. In case, you feel that there is more than one correct response, mark the response which you consider the best. In any case, choose ONLY ONE response for each item.
5. You have to mark your responses ONLY on the separate Answer Sheet provided. See directions in the Answer Sheet.
6. All items carry equal marks.
7. Before you proceed to mark in the Answer Sheet the response to various items in the Test Booklet, you have to fill in some particulars in the Answer Sheet as per instructions sent to you with your Admission Certificate.
8. After you have completed filling in all your responses on the Answer Sheet and the examination has concluded, you should hand over to the Invigilator only the Answer Sheet. You are permitted to take away with you the Test Booklet.
9. Sheets for rough work are appended in the Test Booklet at the end.
10. Penalty for wrong answers :  
THERE WILL BE PENALTY FOR WRONG ANSWERS MARKED BY A CANDIDATE.
  - (i) There are four alternatives for the answer to every question. For each question for which a wrong answer has been given by the candidate, one-third of the marks assigned to that question will be deducted as penalty.
  - (ii) If a candidate gives more than one answer, it will be treated as a wrong answer even if one of the given answers happens to be correct and there will be same penalty as above to that question.
  - (iii) If a question is left blank, i.e., no answer is given by the candidate, there will be no penalty for that question.

DO NOT OPEN THIS TEST BOOKLET UNTIL YOU ARE TOLD TO DO SO



Download FREE UPSC E-BOOKS

FREE!

CLICK HERE

1. A transistor has  $\beta = 105$  and  $I_C = 840 \mu\text{A}$ . What is the value of  $I_B$ ?
  - (a)  $0.008 \mu\text{A}$
  - (b)  $0.08 \mu\text{A}$
  - (c)  $0.8 \mu\text{A}$
  - (d)  $8 \mu\text{A}$
2. What is the power gain of a transistor amplifier, if its current gain is 40 and voltage gain is 25?
  - (a) 100
  - (b) 1200
  - (c) 1000
  - (d) 950
3. Which one of the following statements is **not** correct regarding common-base amplifier?
  - (a) The output is in the same phase as the input alternating signal.
  - (b) It cannot operate at higher frequency as compared to CE amplifier.
  - (c) The current gain is less than unity.
  - (d) Impedance matching is needed when cascading because there is very large difference in the input and output impedances, the input impedance is low and the output high.
4. When the quiescent point of an amplifier is biased just at the cut-off axis, so that only the positive half of the signal input is amplified and the negative half of the signal is cut off, it is referred to as
  - (a) class AB amplification
  - (b) class A amplification
  - (c) class B amplification
  - (d) class C amplification
5. Which one of the following is a disadvantage of CE amplifier?
  - (a) It provides good current as well as voltage gain
  - (b) It provides the maximum power gain of the three configurations
  - (c) It has medium both input and output impedances
  - (d) Its frequency response bandwidth is lower than the amplifiers of the other two configurations
6. Which one of the following consists of op-amp in inverting mode and network of R-C components, and the op-amp being in inverting mode it serves two purposes of amplifying and at its output  $180^\circ$  shifted phase is obtained?
  - (a) Wien's bridge oscillator
  - (b) R-C phase-shift oscillator
  - (c) Triangular wave generator
  - (d) Charging capacitor



7. Which one of the following statements is **not** correct related to oscillators?

- (a) The frequency of a sinusoidal oscillator is determined by the condition that the loop-gain phase shift is zero.
- (b) In every practical oscillator, the loop gain is slightly larger than unity and the amplitude of the oscillations is limited by the onset of non-linearity.
- (c) The condition of unity loop gain  $-A\beta = 1$  is called the Barkhausen criterion.
- (d) Oscillations will be sustained if, at the oscillator frequency, the magnitude of the product of the transfer gain of the amplifier and the magnitude of the feedback factor of the feedback network are less than unity.

8. Which one of the following statements is **not** correct for a transistor?

- (a) The region at the centre is always base region.
- (b) Emitter region is more heavily doped and base region is very lightly doped.
- (c) Collector region is very lightly doped compared to base region.
- (d) Low power input can be converted to a large power output with the help of a small piece of semiconductor without any hassles of preheating and handling of large heat dissipation.

9. For certain of the reverse voltage in a transistor, the effective base width may reduce to zero resulting into the voltage breakdown. This phenomenon is called

- (a) early effect
- (b) avalanche multiplication
- (c) punch through
- (d) zones breakdown

10. An  $n$ -type semiconductor specimen has a Hall coefficient of  $300 \text{ cm}^3/\text{C}$  and its resistivity is  $0.1 \Omega\text{-cm}$ . Its electron mobility is

- (a)  $300 \text{ cm}^2/\text{V-sec}$
- (b)  $30 \text{ cm}^2/\text{V-sec}$
- (c)  $3000 \text{ cm}^2/\text{V-sec}$
- (d)  $3 \text{ cm}^2/\text{V-sec}$

11. Which of the following motors are commonly used in power electronic systems?

1. Synchronous motors
2. d.c. motors
3. d.c. motors with brushes

Select the correct answer using the code given below.

- (a) 1 and 3 only
- (b) 1 and 2 only
- (c) 2 and 3 only
- (d) 1, 2 and 3

12. In P-N junction diode, the reverse saturation current increases by 7.2% by a degree rise in junction temperature (in Celsius) and gets

- (a) halved for every 10 °C rise in temperature
- (b) doubled for every 10 °C rise in temperature
- (c) halved for every 20 °C rise in temperature
- (d) doubled for every 20 °C rise in temperature

13. Which one of the following controllers is to check the status of each device and inform the central processing unit of the status of each?

- (a) Programmable I/O interrupt controller
- (b) DMA controller
- (c) Disk controller
- (d) Pipeline controller

14. Which one of the following bus architectures is used to maximize throughput of video graphics memory?

- (a) EISA bus
- (b) VESA bus
- (c) PCI bus
- (d) MCA bus

15. Which one of the following bus architectures is having maximum data rate (MB/s)?

- (a) VESA bus
- (b) PCI-64 bus
- (c) MCA bus
- (d) EISA bus

16. Which one of the following functions is **not** performed by the USB host controller?

- (a) Configure the scheduling algorithms
- (b) Packet generation
- (c) Serializer/Deserializer
- (d) Process request from device and host

17. Which one of the following layers in PCI express protocol architecture is used for compatibility with PCI, initialization and enumeration of the devices connected to the PCI express?

- (a) PCI express physical layer
- (b) Software layer
- (c) Data link layer
- (d) Hardware layer

18. Which one of the following tools is used to protect critical sections and prevent race conditions?

- (a) Mutex lock
- (b) Semaphore lock
- (c) Spooling lock
- (d) Livelock

19. To arise a deadlock situation, which of the following conditions hold simultaneously in a system?

- 1. Mutual exclusion
- 2. Hold and wait
- 3. Preemption

Select the correct answer using the code given below.

- (a) 1 and 3 only
- (b) 1 and 2 only
- (c) 2 and 3 only
- (d) 1, 2 and 3

20. Which of the following issues are addressed by redundant arrays of independent disks?

- (a) Performance and reliability
- (b) Performance and stability
- (c) Performance and process
- (d) Performance and storage space

21. Stack-oriented machine

- (a) contains any accumulator or general purpose registers
- (b) does not contain only a stack pointer which points to the stack top
- (c) requires any operand address for arithmetic, logical and comparison instructions
- (d) does not contain any accumulator or general purpose registers

22. Virtual memory implements the translation of a program's address space to

- (a) virtual addresses
- (b) physical addresses
- (c) mapping addresses
- (d) page addresses

23. Which one of the following provides an interface to which a client can send a request to perform an action, in response, the server executes the action and sends back results to the client?

- (a) File server system
- (b) Open-source system
- (c) Compute server system
- (d) Peer-to-peer system

24. Which of the following statements are correct regarding multiprocessing architecture?

- 1. It can cause a system to change its memory access model from uniform memory access to non-uniform memory access.
- 2. There are two types of systems such as asymmetric multiprocessing and symmetric multiprocessing.
- 3. It adds CPUs to decrease computing power.

Select the correct answer using the code given below.

- (a) 1 and 3 only
- (b) 1 and 2 only
- (c) 2 and 3 only
- (d) 1, 2 and 3

25. Consider a parallel circuit having three branches—the current in first branch is  $50 \pm 2$  A, in the second branch is  $100 \pm 3$  A and in the third branch is  $200 \pm 5$  A. What is the value of the total current, assuming the errors as standard deviations?

- (a)  $350 \pm 10$  A
- (b)  $350 \pm 3.16$  A
- (c)  $350 \pm 6.16$  A
- (d)  $350 \pm 5$  A



26. Which one of the following is **not** a self-generating type of transducer?

- (a) Bourdon gauge for the measurement of pressure
- (b) Pitot tube for the measurement of fluid flow velocity
- (c) Thermistor for the measurement of temperature
- (d) Photovoltaic cell

27. The approximate range of gauge factor for a semiconductor strain gauge is

- (a) 2-3
- (b) 50-90
- (c) 10-20
- (d) 100-200

28. The approximate pressure range for ionization gauge measuring device is

- (a)  $10^{-8}$  to  $10^{-3}$  torr
- (b)  $10^{-3}$  to  $10^{-2}$  torr
- (c)  $10^{-10}$  to  $10^{-8}$  torr
- (d)  $10^{-2}$  to  $10^{-1}$  torr

29. A half-wave rectifier type a.c. voltmeter is fed with a 20 V r.m.s. signal. What is the equivalent d.c. output voltage?

- (a) 6.4 V
- (b) 9 V
- (c) 12.8 V
- (d) 18 V

30. A D'Arsonval movement has a resistance of 100  $\Omega$  and full deflection current of 2 mA and is used for construction of multirange ammeter as shown in the figure :

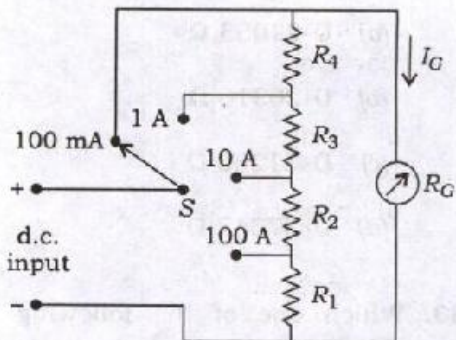

What are the values of resistances  $R_1$ ,  $R_2$ ,  $R_3$  and  $R_4$ , if the shunt resistances are connected as shown in the figure?

- (a)  $R_1 = 0.002 \Omega$ ,  $R_2 = 0.018 \Omega$ ,  
 $R_3 = 0.18 \Omega$  and  $R_4 = 1.836 \Omega$
- (b)  $R_1 = 0.002 \Omega$ ,  $R_2 = 0.18 \Omega$ ,  
 $R_3 = 0.018 \Omega$  and  $R_4 = 1.836 \Omega$
- (c)  $R_1 = 1.836 \Omega$ ,  $R_2 = 0.18 \Omega$ ,  
 $R_3 = 0.018 \Omega$  and  $R_4 = 0.002 \Omega$
- (d)  $R_1 = 1.836 \Omega$ ,  $R_2 = 0.018 \Omega$ ,  
 $R_3 = 0.18 \Omega$  and  $R_4 = 0.02 \Omega$

31. The torque generated in the aluminium disc of induction type energy meter is maximum when the phase difference between the magnetic fields of shunt and series electromagnets is equal to
- 180°
  - 90°
  - 45°
  - 0°
32. A d.c. galvanometer of 4 Ω resistance reads up to 50 mA. What is the value of the resistance in parallel to enable the instrument to read up to 1 A?
- 0.21053 Ω
  - 0.26316 Ω
  - 0.31285 Ω
  - 0.37347 Ω
33. Which one of the following is correct in the feedback circuit, having three resistance and capacitance elements with conditions as  $R_1 = R_2 = R_3 = \bar{R}$  and  $C_1 = C_2 = C_3 = \bar{C}$  for phase-shift oscillator?
- $f = \frac{0.065}{RC}$
  - $f = \frac{0.078}{RC}$
  - $f = \frac{0.045}{RC}$
  - $f = \frac{0.038}{RC}$
34. Which one of the following statements is **not** correct for electro-dynamometer type instrument?
- It can measure a range of currents and voltages up to 10 A and 600 V respectively.
  - The deflecting torque is inversely proportional to the square of the current.
  - It can be used for both a.c. and d.c. systems.
  - It has the same calibration for d.c. instruments as well as a.c. measurements.
35. The controlling torque of a gravity-controlled measuring instrument is directly proportional to
- $\theta$
  - $\cos \theta$
  - $\theta^2$
  - $\sin \theta$



36. The arms of a four-arm bridge  $abcd$ , supplied with sinusoidal voltage, have the following values :

Arm  $ab$  : A resistance of  $200 \Omega$  in parallel with a capacitance of  $1 \mu\text{F}$

Arm  $bc$  :  $400 \Omega$  resistance

Arm  $cd$  :  $1000 \Omega$  resistance

Arm  $da$  : A resistance  $R_2$  in series with a  $2 \mu\text{F}$  capacitance

What are the values of  $R_2$  and the frequency respectively at which the bridge will balance?

- (a)  $200 \Omega$ ,  $456 \text{ Hz}$
- (b)  $400 \Omega$ ,  $398 \text{ Hz}$
- (c)  $200 \Omega$ ,  $398 \text{ Hz}$
- (d)  $400 \Omega$ ,  $456 \text{ Hz}$

37. The Thevenin voltage and resistance across the terminal  $a-b$  of the circuit in the figure respectively are

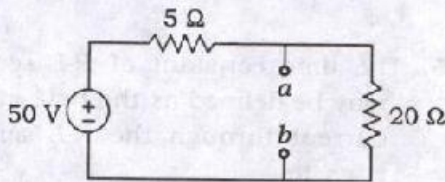

- (a)  $40 \text{ V}$ ,  $4 \Omega$
- (b)  $20 \text{ V}$ ,  $8 \Omega$
- (c)  $40 \text{ V}$ ,  $8 \Omega$
- (d)  $20 \text{ V}$ ,  $4 \Omega$

38. What is  $C_{eq}$  for the given circuit?

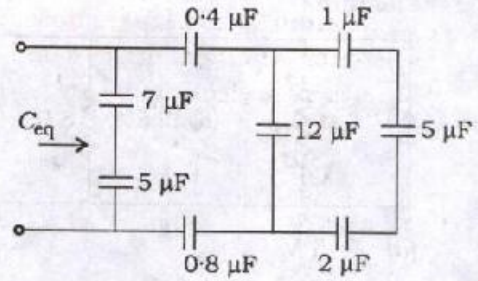

- (a)  $6.18 \mu\text{F}$
- (b)  $3.18 \mu\text{F}$
- (c)  $8.23 \mu\text{F}$
- (d)  $12.67 \mu\text{F}$

39. Consider the following statements with respect to Kirchhoff's laws for a circuit comprising of resistances and independent sources :

1. The number of independent element volt-ampere equations is equal to the number of resistances.
2. The number of independent KVL equations is equal to one more than the number of nodes.
3. The number of independent KVL equations is equal to the number of independent loops.

Which of the above statements is/are **not** correct?

- (a) 1 only
- (b) 2 only
- (c) 2 and 3 only
- (d) 1, 2 and 3

40. What is the voltage  $v$  in the circuit diagram?

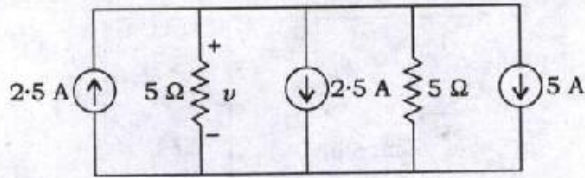

- (a) 7.5 V
- (b) 16.5 V
- (c) 12.5 V
- (d) 14.4 V

41. When angular frequency for d.c. sources is zero, capacitor and inductor will act like respectively

- (a) short circuited, open circuited
- (b) open circuited, short circuited
- (c) open circuited, open circuited
- (d) short circuited, short circuited

42. Which one of the following statements is **not** correct regarding potential due to a point charge?

- (a) It is directly proportional to the magnitude of the charge.
- (b) It is inversely proportional to the distance from the charge.
- (c) It is inversely proportional to the relative permittivity of the medium in which the charge is placed.
- (d) It is directly proportional to the electric field intensity.

43. The relation between electric flux density ( $D$ ) and field intensity ( $E$ ) with absolute and relative permittivity is expressed as

- (a)  $E = \frac{\epsilon_0 \epsilon_r}{D}$
- (b)  $E = \frac{D}{\epsilon_0 \epsilon_r}$
- (c)  $E = \frac{D \epsilon_0}{\epsilon_r}$
- (d)  $E = \frac{D \epsilon_r}{\epsilon_0}$

44. If  $L$  is self-inductance,  $I$  is current,  $\lambda$  is flux linkage of a magnetic field, then the energy stored in the magnetic field is

- (a)  $0.5\lambda^2 / L$
- (b)  $2\lambda^2 / L$
- (c)  $0.5\lambda / L^2$
- (d)  $2\lambda / L^2$

45. The time constant of  $R$ - $L$  series circuit may be defined as the time at which the current through the  $R$ - $L$  series circuit rises to

- (a) 36.8% of steady-state value
- (b) 63.2% of steady-state value
- (c) 23.2% of initial value
- (d) 46.8% of initial value



46. Transient disturbance is produced in a circuit whenever

- (a) currents in electrical circuit are associated with resistors
- (b) circuit is suddenly connected to or disconnected from the supply
- (c) the source is overdamped
- (d) the source is underdamped

47. Choke coils are made of iron core, because

- (a) it has less loss in iron cores
- (b) large-valued flux densities can be produced in iron cores
- (c) it is easily available in the market
- (d) it has laminated core with high resistance

48. At off-resonance frequencies in parallel resonant circuit, the phase angle is greater than

- (a)  $0^\circ$
- (b)  $30^\circ$
- (c)  $60^\circ$
- (d)  $90^\circ$

49. Which one of the following defects might be thought of as being formed by a cation leaving its normal position and moving into an interstitial site?

- (a) Schottky defect
- (b) Frenkel defect
- (c) Crystallographic defect
- (d) Stoichiometric defect

50. Which of the following classifications are correct with reference to the various types of imperfections in a semiconductor?

1. Substitutional
2. Vacancies
3. Interstitial

Select the correct answer using the code given below.

- (a) 1 and 2 only
- (b) 2 and 3 only
- (c) 1 and 3 only
- (d) 1, 2 and 3

51. Which one of the following statements is **not** correct regarding superconductivity of material?

- (a) Superconducting compounds and alloys do not necessarily have compounds which are themselves superconducting.
- (b) The metals which are very good conductors at room temperature do not exhibit superconducting properties.
- (c) The metals and compounds which are superconducting are rather bad conductors at ordinary temperature.
- (d) Monovalent metals, ferromagnetic and anti-ferromagnetic metals are superconducting.

52. According to Bragg's law, if an electromagnetic wave is diffracted when it is passed through a series of small slits spaced a distance  $d$  apart and order of diffraction is  $n$  and if the angle between the diffracted beam and incident beam is  $2\theta$ , then the relationship between the wavelength  $\lambda$  and this angle of diffraction is

- (a)  $n\lambda = 2d \sin \theta$
- (b)  $\lambda = 2dn \sin \theta$
- (c)  $\lambda d = n \sin 2\theta$
- (d)  $n\lambda = d \sin 2\theta$

53. What is the approximate diameter of a copper wire of length 100 m, if it is to be used as winding material in a transformer such that the resistance of the whole winding is  $2 \Omega$ ? (Take resistivity of copper as  $1.7 \times 10^{-8} \Omega\text{-m}$ )

- (a) 0.25 mm
- (b) 1.05 mm
- (c) 2.25 mm
- (d) 3.05 mm

54. The temperature above which the ferromagnetic materials lose their magnetic properties is called

- (a) saturation point
- (b) breakdown point
- (c) Curie point
- (d) peak point

55. There are some metals and chemical compounds whose resistivity becomes zero when their temperature is brought near 0 K ( $-273^\circ\text{C}$ ). Such metals or compounds are said to have attained

- (a) piezoelectricity
- (b) superconductivity
- (c) semiconductivity
- (d) electromagnetism



56. A blue lamp emits light of mean wavelength of 4500 Å. The lamp is rated at 150 W and 8% of the energy appears as emitted light. How many photons are emitted by the lamp per second? (Take  $h = 6.625 \times 10^{-34}$  J-sec and  $c = 3 \times 10^8$  m/sec)

- (a)  $10.55 \times 10^{18}$
- (b)  $13.62 \times 10^{18}$
- (c)  $27.15 \times 10^{18}$
- (d)  $33.25 \times 10^{18}$

57. What is the energy lost per hour in a specimen of iron subjected to magnetization at 50 c/s, if the specimen weighs 50 kg and the hysteresis loop is equivalent in area to  $250 \text{ J/m}^3$  and the density of iron is  $7500 \text{ kg/m}^3$ ?

- (a)  $3 \times 10^5$  J
- (b)  $4 \times 10^5$  J
- (c)  $5 \times 10^5$  J
- (d)  $6 \times 10^5$  J

58. A good insulating material should possess which of the following characteristics?

1. High dielectric strength
2. Low permittivity
3. Low thermal strength

Select the correct answer using the code given below.

- (a) 1 and 2 only
- (b) 1 and 3 only
- (c) 2 and 3 only
- (d) 1, 2 and 3

59. Most substances are not magnets, because

- (a) they do not have sufficient energy to produce magnetic behaviour
- (b) their electrons do not move truly
- (c) the electrons usually pair up with their spins opposite to each other, so that their fields cancel each other
- (d) their electrons strongly bind to the nucleus as they have more number of protons than electrons

60. Whenever a particle has angular momentum, it will contribute to permanent dipole moment. Which one of the following does **not** contribute to the angular momentum of an atom?

- (a) Orbital angular momentum of electron
- (b) Proton spin angular momentum
- (c) Electron spin angular momentum
- (d) Nuclear spin angular momentum

61. A workshop has several machines. During a typical month, two machines will break down. The probability of more than two machines will break down in a month is

(a)  $1 - 3e^{-2}$

(b)  $1 - 4e^{-2}$

(c)  $1 - 5e^{-2}$

(d)  $1 - 6e^{-2}$

62. Villages A, B, C and D are connected by overhead telephone lines joining AB, AC, BC, BD and CD. As a result of severe gales, there is a probability  $p$  (the same for each link) that any particular link is broken. Then the probability that a call can be made from A to B is

(a)  $1 - p^2 - 2p^3 + 3p^4 - p^5$

(b)  $1 + 2p^2 - 2p^3 + 4p^4 - 2p^5$

(c)  $1 - 3p^2 + 2p^3 - 3p^4 + p^5$

(d)  $1 + 4p^2 + 2p^3 - 4p^4 + 2p^5$

63. What is regression line of Y on X for the following six pairs of observations?

$i$	1	2	3	4	5	6
$x_i$	1	3	4	5	7	8
$y_i$	2	8	9	10	14	19

(a)  $Y = 1.18X - 0.49$

(b)  $Y = 1.18X - 0.16$

(c)  $Y = 2.18X + 0.49$

(d)  $Y = 2.18X + 0.16$

64. A bag contains 50 balls of which 10 are red and the remainder black. If two balls are drawn successively from the bag at random, what is the probability of selecting one red and one black ball?

(a)  $\frac{9}{245}$

(b)  $\frac{156}{245}$

(c)  $\frac{16}{49}$

(d)  $\frac{156}{49}$

65. A random variable  $y$  has a known probability distribution given by

$y$	2	4	6	8	10
$P(y)$	0.17	0.23	0.2	0.3	0.1

Then the expected value of  $y$  is

(a) 7.67

(b) 6.88

(c) 5.86

(d) 4.89

66. The Fourier series for  $f(x) = \sin^2 x$  defined over the range  $-\pi \leq x \leq \pi$  is

(a)  $\frac{1}{2} - \frac{\cos 2x}{2}$

(b)  $1 + \cos 2x$

(c)  $\frac{1}{2} - \frac{\cos x}{2}$

(d)  $\frac{\cos 2x}{2} + \frac{1}{2}$

67. What is the general solution of the partial differential equation

$$\frac{\partial \psi}{\partial x} + 2 \frac{\partial \psi}{\partial y} + (2x - y)\psi = 0 ?$$

(a)  $\psi(x, y) = f(2x - y)e^{-(2x^2 + 2y^2 - 3xy)/5}$

(b)  $\psi(x, y) = f(2x - y)e^{-(2x^2 - 2y^2 + 3xy)/5}$

(c)  $\psi(x, y) = f(2x - y)e^{-(2x^2 + 2y^2 + 3xy)/5}$

(d)  $\psi(x, y) = f(2x - y)e^{-(2x^2 - 2y^2 + 3xy)/5}$

68. The functions  $f(x, t)$  and  $F(x)$  are defined by  $f(x, t) = e^{-xt}$  and  $F(x) = \int_0^x f(x, t) dt$ .

Then  $\frac{dF}{dx} =$

(a)  $f(x, t) + \int_0^x \frac{\partial f(x, t)}{\partial x} dt$

(b)  $f(x, x) + \int_0^x \frac{\partial f(x, t)}{\partial x} dt$

(c)  $f(0, 0) + \int_0^x \frac{\partial f(x, t)}{\partial x} dt$

(d)  $f(t, t) + \int_0^x \frac{\partial f(x, t)}{\partial x} dt$

69. The distances of the variable point  $P$ , which has coordinates  $x, y, z$ , from the fixed points  $(0, 0, 1)$  and  $(0, 0, -1)$  are denoted by  $u$  and  $v$  respectively. New variables  $\xi, \eta, \phi$  are defined by  $\xi = \frac{1}{2}(u + v), \eta = \frac{1}{2}(u - v)$  and  $\phi$  is the angle between the plane  $y = 0$  and the plane containing the three points, i.e.,  $\phi = \tan^{-1}\left(\frac{y}{x}\right)$  over  $1 \leq \xi < \infty, -1 \leq \eta < 1, 0 \leq \phi < 2\pi$ . The Jacobian of  $\frac{\partial(\xi, \eta, \phi)}{\partial(x, y, z)}$  has the value  $(\xi^2 - \eta^2)^{-1}$ , then

$$\iiint_{\text{all space}} \frac{(u-v)^2}{uv} \exp\left(-\frac{u+v}{2}\right) dx dy dz =$$

(a)  $\frac{16\pi}{e}$

(b)  $\frac{8\pi}{3e}$

(c)  $\frac{16\pi}{3e}$

(d)  $\frac{8\pi}{e}$

70. The function

$$f(x, y) = x^3 - 12xy + 48x + by^2, \quad b \neq 0$$

has two, one or zero stationary points, according to whether  $|b|$  is

(a) less than, equal to or greater than 3

(b) less than, equal to or greater than 4

(c) less than, equal to or greater than 8

(d) less than, equal to or greater than 2

71. What are the values of  $\alpha$  and  $\beta$  that make

$$dF(x, y) = \left( \frac{1}{x^2 + 2} + \frac{\alpha}{y} \right) dx + (xy^\beta + 1) dy$$

an exact differential equation?

- (a)  $\alpha = -1, \beta = -2$
- (b)  $\alpha = 1, \beta = -2$
- (c)  $\alpha = -1, \beta = 2$
- (d)  $\alpha = -2, \beta = -1$

72.  $A$  and  $B$  are real non-zero  $3 \times 3$  matrices and satisfy the equation  $(AB)^T + B^{-1}A = 0$ . If  $B$  is orthogonal, then  $A$  is

- (a) symmetric
- (b) anti-symmetric
- (c) Hermitian
- (d) anti-Hermitian

73. Consider a buck converter with the controlled switch as MOSFET and the uncontrolled switch as diode, the input to the buck converter is 60 V. The MOSFET is turned on for 20  $\mu$ sec and turned off for 10  $\mu$ sec periodically. Assuming ideal components, the output voltage of the buck converter is

- (a) 20 V
- (b) 30 V
- (c) 40 V
- (d) 50 V

74. Consider the following statements related to d.c.-d.c. converters :

1. The polarity of output voltage and input voltage of a single-ended primary inductance converter is opposite.
2. The polarity of output voltage and input voltage of a Cuk converter is opposite.
3. The polarity of output voltage and input voltage of a buck-boost converter is same.
4. The polarity of output voltage and input voltage of a boost converter is same.

Which of the above statements are correct?

- (a) 1, 2, 3 and 4
- (b) 1, 2 and 3 only
- (c) 1 and 3 only
- (d) 2 and 4 only

75. In d.c. power supplies, the switching frequency is much greater than

- (a) the d.c. power source frequency, enabling the transformer to be small
- (b) the d.c. power source frequency, enabling the transformer to be large
- (c) the a.c. power source frequency, enabling the transformer to be large
- (d) the a.c. power source frequency, enabling the transformer to be small



76. Which one of the following is the circuit symbol of  $p$ -channel IGBT?

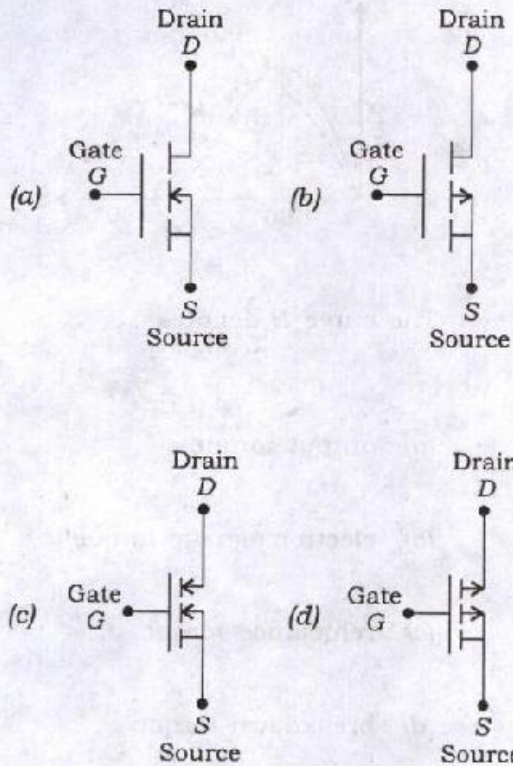

77. The regenerative action does **not** take place in which type of triggering method to turn on the SCR?

- (a) Thermal triggering
- (b) High forward voltage triggering
- (c) Light triggering
- (d) Gate triggering

78. Which one of the following is also known as resonant commutation?

- (a) Class A commutation
- (b) Class C commutation
- (c) Class D commutation
- (d) Class E commutation

79. Which one of the following is a current-controlled device?

- (a) MOSFET
- (b) SIT
- (c) MCT
- (d) GTO

80. In line frequency phase-controlled converters and single-quadrant step-down switch-mode d.c.-d.c. converters, the output current can become

- (a) discontinuous at light loads on the motor
- (b) zero current
- (c) higher than the rated speed of the motor
- (d) to match the motor load inertia

81. When a separately excited d.c. motor is to be controlled from a three-phase supply fed from controlled rectifier in only first quadrant, which one of the following converters is used to serve the purpose?

- (a) Half-wave converter
- (b) Full converter
- (c) Semiconverter
- (d) Dual converter

82. In case of a squirrel-cage induction motor using three-phase bridge inverter, which one of the following statements is correct for speed control?

- (a) If frequency increases, then starting torque decreases with constant supply voltage.
- (b) If frequency increases, then starting torque increases with constant supply voltage.
- (c) If frequency decreases, then starting torque decreases with constant supply voltage.
- (d) If frequency decreases, then starting torque increases with constant supply voltage.

83. The following characteristics are drawn for salient-pole synchronous motor :

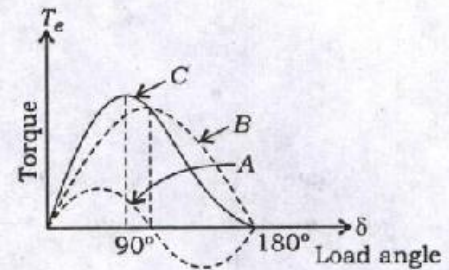

The curve B denotes

- (a) output torque
- (b) electromagnetic torque
- (c) reluctance torque
- (d) breakdown torque

84. While finding various factors of single-phase diode rectifiers, the transformer utilization factor of a half-wave rectifier is

- (a) 0.482
- (b) 0.572
- (c) 0.286
- (d) 1.11

85. The positive sequence impedance component of three unequal impedances  $Z_a$ ,  $Z_b$  and  $Z_c$  is

(a)  $\frac{1}{3}(Z_a + aZ_b + a^2Z_c)$

(b)  $\frac{1}{3}(Z_a + a^2Z_b + aZ_c)$

(c)  $\frac{1}{3}(Z_a + Z_b + a^2Z_c)$

(d)  $\frac{1}{3}(Z_a + aZ_b + Z_c)$

86. Which one of the following wiring systems is commonly used for light/fan load in domestic and commercial buildings?

(a) Lead sheathed wiring

(b) Conduit wiring

(c) PVC wiring

(d) Cleat wiring

87. Which one of the following is **not** an advantage in using bundle conductors?

(a) Reduced corona loss

(b) Reduced radio interference

(c) Increased voltage gradient

(d) Reduced surge impedance

88. Which one of the following is **not** a method of voltage control in power systems?

(a) Booster transformer

(b) Tap-changing transformer

(c) Series capacitor

(d) Shunt inductor

89. An inductance of  $800 \mu\text{H}$  connects two sections of a transmission line each having a surge impedance of  $200 \Omega$ . A  $500 \text{ kV}$ ,  $2 \mu\text{sec}$  rectangular surge travels along the line towards the inductance. What is the maximum value of the transmitted wave?

(a)  $500 \times \left[ \frac{e-1}{e} \right] \text{ kV}$

(b)  $500 \times \left[ \frac{e+1}{e} \right] \text{ kV}$

(c)  $250 \times \left[ \frac{e-1}{e} \right] \text{ kV}$

(d)  $250 \times \left[ \frac{e+1}{e} \right] \text{ kV}$

90. The faults on power systems are analyzed easily by making use of

(a) superposition theorem

(b) substitution theorem

(c) Thevenin's theorem

(d) Millman's theorem



91. Which one of the following is **not** a basic functional characteristic of a protective relay?
- (a) Reliability
  - (b) Sensitivity
  - (c) Speed
  - (d) Linearity
92. In a system of 132 kV, the line-to-ground capacitance is  $0.01 \mu\text{F}$  and the inductance is 4 H. What is the voltage appearing across the pole of a circuit breaker if the instantaneous value of magnetizing current of 5 A is interrupted?
- (a) 50 kV
  - (b)  $100/\sqrt{2}$  kV
  - (c) 100 kV
  - (d)  $100\sqrt{2}$  kV
93. Which one of the following tests does **not** come under the testing types of circuit breaker?
- (a) Short-circuit test
  - (b) Open-circuit test
  - (c) Dielectric test
  - (d) Thermal test
94. In a power system, the maximum power can be transferred from one end to another end when the reactance of the line is
- (a)  $\sqrt{3}$  times of the resistance
  - (b)  $\sqrt{2}$  times of the resistance
  - (c) triple the resistance
  - (d) double the resistance
95. A 50 Hz, four-pole turbogenerator rated at 30 MVA, 13.2 kV has an inertia constant of  $H = 9.0 \text{ kW-sec/kVA}$ . What is the KE stored in the rotor at synchronous speed?
- (a) 135 MJ
  - (b) 180 MJ
  - (c) 270 MJ
  - (d) 360 MJ
96. Which one of the following is **not** an example of renewable energy?
- (a) Solar
  - (b) Wind
  - (c) Geothermal
  - (d) Nuclear

97. There are additional losses that arise from the non-uniform current distribution in the conductors and the core losses generated in the iron due to the distortion of the magnetic flux distribution from the load currents. Such losses are known as

- (a) steel losses
- (b) frictional losses
- (c) stray load losses
- (d) windage losses

98. If the magnetic core has a constant permeability by making air as media for a coil current and the resultant flux linkage, then

- (a) the energy and coenergy are equal
- (b) the energy is greater than the coenergy
- (c) the energy is less than the coenergy
- (d) the coenergy is not developed

99. The structure of d.c. commutator machine is generally designed with

- (a) non-salient stator and salient rotor
- (b) salient stator and non-salient rotor
- (c) salient stator and salient rotor
- (d) non-salient stator and non-salient rotor

100. The steady-state external performance characteristic of a d.c. generator has the relationship between

- (a) generated e.m.f. and field current at constant speed
- (b) terminal voltage and field current, with constant armature current and speed
- (c) generated e.m.f. and field current, with constant armature current and speed
- (d) terminal voltage and load current at constant speed

101. A 250 V, 50 kW, short-shunt compound d.c. generator has the following data : armature resistance =  $0.05 \Omega$ , series field resistance =  $0.05 \Omega$ , shunt field resistance =  $130 \Omega$  and 2 V is the total brush contact drop. What is the value of the total current supplied by the generator?

- (a) 0.2 A
- (b) 2 A
- (c) 0.2 kA
- (d) 2 kA

102. In generating mode, an induction machine operates as a generator with a shaft speed which is greater than the synchronous speed, if the slip is

- (a) zero
- (b) unity
- (c) greater than unity
- (d) less than zero

103. A three-phase, 60 Hz, 25 HP, wye-connected induction motor operates at a shaft speed of almost 1800 r.p.m. at no load and 1650 r.p.m. at full load. The number of poles of the motor is

- (a) 2
- (b) 3.33
- (c) 4
- (d) 6.66

104. A three-phase, 13.2 kV, 60 Hz, 50 MVA, wye-connected cylindrical rotor synchronous generator has an armature reactance of  $2.19 \Omega$  per phase. The leakage reactance is 0.137 times the armature reactance. The armature resistance is small enough to be negligible. Also ignore the saturation. Assume that the generator delivers full-load current at the rated voltage and 0.8 lagging power factor. The synchronous reactance per phase is

- (a)  $0.32 \Omega$
- (b)  $2.32 \Omega$
- (c)  $2.73 \Omega$
- (d)  $2.49 \Omega$

105. For the commutated d.c. machine stator, it has riveted poles and the ends of the poles are called

- (a) pole shoe
- (b) pole face
- (c) pole arc
- (d) pole gap



106. In a lap winding, there are always as many paths in parallel through the armature winding as there are a number of poles. In such a lap winding, the current in each armature coil is

- (a) one and one-half of the armature terminal current
- (b) half of the armature terminal current
- (c) equal to the armature terminal current divided by the number of poles
- (d) equal to the number of poles divided by the armature terminal current

107. A four-pole d.c. machine armature has 54 slots. It is lap-wound with single-turn coils. How many armature coils are required?

- (a) 27
- (b) 54
- (c) 81
- (d) 108

108. A shunt d.c. motor is rated for 230 V, 1350 r.p.m., 10 HP, the line current  $I_L = 37.5$  A and the field current  $I_f = 0.75$  A. It is known that the armature resistance  $R_a = 0.35 \Omega$  and the power dissipated across field winding  $P_{fw} = 519$  W at rated speed. The shunt d.c. motor is to be equipped with the manually operated variable resistor starter. What is the maximum allowable armature current in starting resistance  $R_{st}$  to assure that the initial armature current does not exceed 150 percent of the rated value?

- (a) 18.125 A
- (b) 27.125 A
- (c) 36.125 A
- (d) 55.125 A

109. Which one of the following statements is correct regarding lead or lag compensation?

- (a) The lag compensator improves the steady-state performance of the system.
- (b) The lead compensation becomes effective when the phase angle of uncompensated system decreases rapidly near the gain crossover frequency.
- (c) Choose the lead compensator when reduced noise level is required.
- (d) The combination of decreased open-loop gain and lead compensator improves steady-state error and phase margin.

110. Consider the following statements for phase margin :

1. Phase margin is defined as the amount of additional phase lag at the gain crossover frequency required to bring the system to the verge of instability.
2. The phase margin is always positive for stable feedback systems.
3. The phase margin is always negative for stable feedback systems.

Which of the above statements is/are correct?

- (a) 1 and 2
- (b) 1 and 3
- (c) 1 only
- (d) 3 only

111. Consider the following statements for minimum and non-minimum phase systems :

1. Non-minimum phase systems have poles and/or zeros in the right half of the s-plane (RHP) of their transfer functions.
2. Minimum phase systems have no poles or zeros in the right half of the s-plane (RHP) of their transfer functions.
3. The modulus of the phase response for a non-minimum phase system is always larger than that for a system with minimum phase behaviour, though both may have the same amplitude response.

Which of the above statements are correct?

- (a) 1 and 2 only
- (b) 2 and 3 only
- (c) 1 and 3 only
- (d) 1, 2 and 3

112. Consider a system described by

$$\begin{bmatrix} \dot{x}_1 \\ \dot{x}_2 \end{bmatrix} = \begin{bmatrix} 1 & 1 \\ -2 & -1 \end{bmatrix} \begin{bmatrix} x_1 \\ x_2 \end{bmatrix} + \begin{bmatrix} 0 \\ 1 \end{bmatrix} u$$

$$y = [1 \ 0] \begin{bmatrix} x_1 \\ x_2 \end{bmatrix}$$

Which one of the following is correct?

- (a) The system is controllable only
- (b) The system is observable only
- (c) The system is controllable and observable
- (d) The system is neither controllable nor observable

113. What is the state-transition matrix  $\Phi(t)$  of the following system?

$$\begin{bmatrix} \dot{x}_1 \\ \dot{x}_2 \end{bmatrix} = \begin{bmatrix} 0 & 1 \\ -2 & -3 \end{bmatrix} \begin{bmatrix} x_1 \\ x_2 \end{bmatrix}$$

$$(a) \Phi(t) = \begin{bmatrix} e^{-t} - e^{-2t} & e^{-t} - e^{-2t} \\ -2e^{-t} + 2e^{-2t} & -e^{-t} + 2e^{-2t} \end{bmatrix}$$

$$(b) \Phi(t) = \begin{bmatrix} 2e^{-t} - e^{-2t} & e^{-t} - e^{-2t} \\ -2e^{-t} + 2e^{-2t} & -e^{-t} + 2e^{-2t} \end{bmatrix}$$

$$(c) \Phi(t) = \begin{bmatrix} 2e^{-t} - e^{-2t} & e^{-t} - e^{-2t} \\ -e^{-t} + e^{-2t} & -e^{-t} + e^{-2t} \end{bmatrix}$$

$$(d) \Phi(t) = \begin{bmatrix} 2e^{-t} - 2e^{-2t} & 2e^{-t} - e^{-2t} \\ -2e^{-t} + 2e^{-2t} & -2e^{-t} + 2e^{-2t} \end{bmatrix}$$



114. In the system shown in the figure, the numerical values of  $m$ ,  $b$  and  $k$  are given as  $m = 1 \text{ kg}$ ,  $b = 2 \text{ N-sec/m}$  and  $k = 100 \text{ N/m}$ . The mass is displaced  $0.05 \text{ m}$  and released without initial velocity. What is the frequency observed in the vibration, if the displacement  $x$  is measured from the equilibrium position?

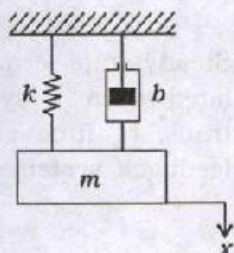

- (a) 6.23 rad/sec
- (b) 7.76 rad/sec
- (c) 9.95 rad/sec
- (d) 8.78 rad/sec

115. A feedback control system is shown in the figure. What is the value of  $K$  for unit ramp input so that the system will have damping ratio of 0.5?

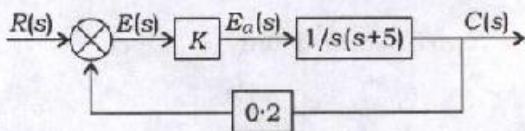

- (a) 50
- (b) 150
- (c) 125
- (d) 25

116. Consider the following network :

$$G(s) = \frac{s + \frac{1}{T_1}}{s + \frac{1}{T_2}}$$

Which of the following conditions is/are correct?

1. If  $T_1 > T_2$ , then the network is a lead network.
2. If  $T_1 < T_2$ , then the network is a lag network.
3. If  $T_1 > T_2$ , then the network is a lag network.
4. If  $T_1 < T_2$ , then the network is a lead network.

Select the correct answer using the code given below.

- (a) 1 only
- (b) 2 only
- (c) 1 and 2
- (d) 3 and 4

117. Consider the system shown in the figure. What is the value of  $a$  such that the damping ratio of the dominant closed poles is 0.5?

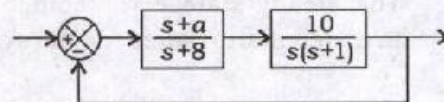

- (a) 0.6
- (b) 1.4
- (c) 1.2
- (d) 2.8

118. Consider the closed-loop system shown in the figure. What is the critical value of  $K$  for stability by the use of the Nyquist stability criterion?

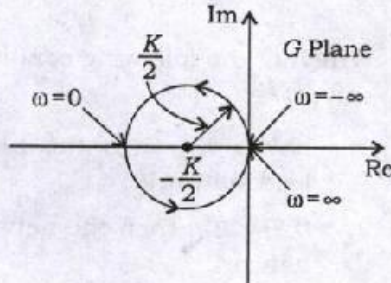

- (a) 0.1
- (b) 0.2
- (c) 1
- (d) 0.5

119. In the feedback control system shown in the figure,  $D(s)$  is step disturbance,  $R(s)$  is input and  $C(s)$  is output :

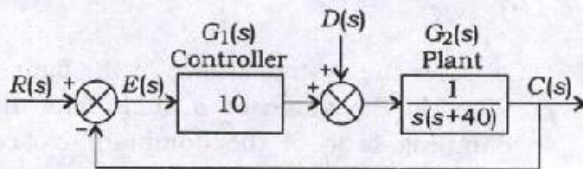

The steady-state error component due to a step disturbance for the system is

- (a) - 0.10
- (b) - 0.25
- (c) 10
- (d) 25

120. Consider the following statements related to steady-state error for a control system :

1. Steady-state error can be calculated from a system's closed-loop transfer function for a unity feedback system.
2. Steady-state error can be calculated from a system's open-loop transfer function for a unity feedback system.
3. Steady-state error is the difference between the input and the output for a prescribed test input as time tends to infinity.
4. Many steady-state errors in control systems can arise from non-linear sources.

Which of the above statements are correct?

- (a) 1 and 3 only
- (b) 1, 3 and 4 only
- (c) 2 and 4 only
- (d) 1, 2, 3 and 4

121. What is the z-transform of discrete-time unit step signal  $u(n)$ ?

(a)  $\frac{z}{z+1}, |z| > 1$

(b)  $\frac{1}{z+1}, |z| > 1$

(c)  $\frac{z}{z-1}, |z| > 1$

(d)  $\frac{1}{z-1}, |z| > 1$

122. Consider the following statements for quarter-wave symmetry :

A periodic function possesses a quarter-wave symmetry, if

1. it has either odd or even symmetry
2. it has half-wave symmetry

Which of the above statements is/are correct?

(a) Both 1 and 2

(b) Neither 1 nor 2

(c) 1 only

(d) 2 only

123. What is the inverse discrete-time Fourier transform of the frequency domain representation shown in the figure?

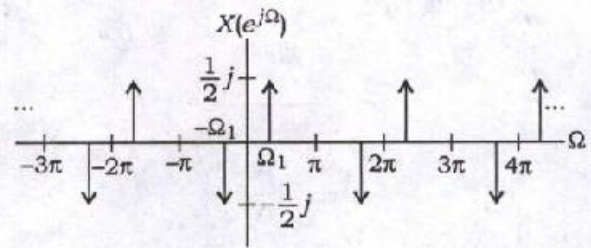

(a)  $x[n] = \frac{\pi}{2} \sin(\Omega_1 n)$

(b)  $x[n] = \frac{3}{2\pi} \sin(\Omega_1 n)$

(c)  $x[n] = \frac{1}{\pi} \sin(\Omega_1 n)$

(d)  $x[n] = \frac{1}{2\pi} \sin(\Omega_1 n)$

124. What is the solution for aperiodic signal  $x(t)$  as shown in the figure?

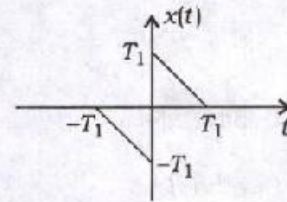

(a)  $j \left( \frac{3 \sin(\omega T_1)}{\omega^2} - \frac{2T_1}{\omega} \right)$

(b)  $j \left( \frac{3 \sin(\omega T_1)}{\omega} - \frac{3T_1}{\omega^2} \right)$

(c)  $j \left( \frac{2 \sin(\omega T_1)}{\omega^2} - \frac{2T_1}{\omega} \right)$

(d)  $j \left( \frac{2 \sin(\omega T_1)}{\omega} - \frac{3T_1}{\omega^2} \right)$

125. For discrete-time sinc function, what is the inverse discrete-time Fourier transform of the function as shown in the figure?

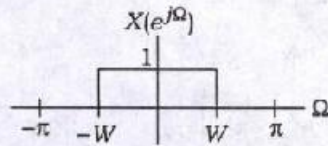

- (a)  $x[n] = \frac{W}{\pi} \text{sinc}\left(\frac{Wn}{2\pi}\right)$
- (b)  $x[n] = \frac{W}{2\pi} \text{sinc}\left(\frac{Wn}{\pi}\right)$
- (c)  $x[n] = \frac{W}{\pi} \text{sinc}\left(\frac{Wn}{\pi}\right)$
- (d)  $x[n] = \frac{2W}{\pi} \text{sinc}\left(\frac{Wn}{2\pi}\right)$

126. What is the Fourier transform  $G(\omega)$  of the signal of  $g(t) = \frac{1}{1+jt}$ ?

- (a)  $2\pi e^{\omega} u(-\omega)$
- (b)  $\pi e^{\omega} u(-\omega)$
- (c)  $0.5\pi e^{\omega} u(-\omega)$
- (d)  $3\pi e^{\omega} u(-\omega)$

127. What is the convolution of the following two signals?

$$x(t) = \begin{cases} 1, & -1 < t < 1 \\ 0, & \text{elsewhere} \end{cases} \quad \text{and} \quad h(t) = \delta(t+1) + 2\delta(t+2)$$

- (a)  $y(t) = x(t+1) + 2x(t-2)$
- (b)  $y(t) = x(t-1) + 2x(t+2)$
- (c)  $y(t) = x(t+1) + 2x(t+2)$
- (d)  $y(t) = x(t-1) + 2x(t-2)$

128. What is the bilateral z-transform of the signal  $x(n) = a^{n+1}u(n+1)$ ?

- (a)  $\frac{z}{1-az^{-1}}, |z| > |a|$
- (b)  $\frac{z}{1+az^{-1}}, |z| > |a|$
- (c)  $\frac{1}{1-az^{-1}}, |z| > |a|$
- (d)  $\frac{1}{1+az^{-1}}, |z| > |a|$

129. Which one of the following statements is **not** correct for convolution?

- (a) The convolution of an odd and an even function is an odd function.
- (b) The convolution of two odd functions is an even function.
- (c) The convolution of two even functions is an even function.
- (d) The convolution of two odd functions is an odd function.

130. The sampling frequency of the signal  $g(t) = \text{sinc}^2(200t)$  is

- (a) 100 Hz
- (b) 200 Hz
- (c) 400 Hz
- (d) 800 Hz

131. What is the final value of the function  $f(t) = e^{-2t} \sin 5t u(t)$  ?

- (a) 0
- (b) 1
- (c) 5
- (d)  $\infty$

132. If a discrete signal represented by  $x(n) = \alpha^n u(n)$ , then what is the value of the signal  $g(n) = x(n) - \alpha x(n-1)$  ?

- (a)  $g(n) = \delta(n)$
- (b)  $g(n) = \delta(n-1)$
- (c)  $g(n) = \alpha \delta(n-1)$
- (d)  $g(n) = \delta(n-\alpha)$

133. For an amplitude modulated double sideband full carrier wave, a peak unmodulated carrier voltage  $V_c = 10V_p$ , a load resistance  $R_L = 10 \Omega$  and a modulation coefficient  $m = 1$ . What is the total power of the modulated wave?

- (a) 7.5 W
- (b) 2.5 W
- (c) 1.25 W
- (d) 5.0 W

134. For a Citizens band receiver using high-side injection with an RF carrier of 27 MHz and an IF centre frequency of 455 kHz, what is the image frequency?

- (a) 24.55 MHz
- (b) 27.91 MHz
- (c) 28.45 MHz
- (d) 29.65 MHz

135. Which of the following statements are correct to improve the noise figure of a receiver?

1. The devices used for the amplifiers and mixer stages must produce low noise.
2. The receiver can be operated at low temperatures.
3. High-gain amplifiers are used to improve the noise figure.
4. The diodes and FETs are preferred to improve the noise figure.

Select the correct answer using the code given below.

- (a) 1 and 2 only
- (b) 3 and 4 only
- (c) 1, 3 and 4 only
- (d) 1, 2, 3 and 4

136. Any device or circuit whose output is not a linear variation with the input can be used as

(a) an RF amplifier

(b) a mixer

(c) an IF amplifier

(d) a local oscillator

137. In the receiver parameter, fidelity is a measure of

(a) the ability of the receiver to accept a given band of frequencies and reject all other frequencies

(b) the minimum radio frequency signal level that can be detected at the input to the receiver and still produces a usable demodulated signal

(c) the ability of a communication system to produce, at the output of the receiver, an exact replica of the original source information

(d) the difference in decibels between the minimum input level necessary to discern a signal and the input level that will overdrive the receiver and produce distortion

138. Which one of the following statements is correct regarding tuned radio frequency receiver?

(a) The bandwidth is inconsistent and varies with centre frequency when tuned over a wide range of input frequencies.

(b) It is stable due to the large number of RF amplifiers all tuned to the same centre frequency.

(c) The gain is uniform over a very wide frequency range.

(d) It has a very low sensitivity.

139. Which one of the following is a figure of merit used to indicate how much the signal-to-noise ratio deteriorates as a signal passes through a circuit or series of circuits?

(a) Impulse noise

(b) Noise figure

(c) Correlated noise

(d) Noise temperature

**140.** Consider the following statements related to the source coding :

1. A conversion of the output of a discrete memoryless source (DMS) into a sequence of binary symbols is called source coding.
2. The source code efficiency ( $\eta$ ) is defined as  $\eta = \frac{L_{\min}}{L}$ , where  $L_{\min}$  is the minimum possible value of  $L$ , and  $L$  is the average codeword length.
3. The code redundancy ( $\gamma$ ) is defined as  $\gamma = 1 + \eta$ .

Which of the above statements are correct?

- (a) 1 and 2 only
- (b) 2 and 3 only
- (c) 1 and 3 only
- (d) 1, 2 and 3

**141.** Consider the following statements regarding differential pulse-code modulator :

1. The differential pulse-code modulator system employs a predictor.
2. It needs far fewer bits per each error sample than what would have been needed for the original samples themselves.
3. It will have larger dynamic range than the original message itself.

Select the correct statements using the code given below.

- (a) 1 and 3 only
- (b) 2 and 3 only
- (c) 1 and 2 only
- (d) 1, 2 and 3

**142.** How many minimum number of samples are required to exactly describe the following signal?

$$x(t) = 10\cos(6\pi t) + 4\sin(8\pi t)$$

- (a) 4 samples per second
- (b) 6 samples per second
- (c) 8 samples per second
- (d) 2 samples per second

**143.** Which one of the following is **not** a property of a Gaussian random process?

- (a) A Gaussian process is completely described by its mean and auto-correlation
- (b) If a Gaussian process is wide-sense stationary, then it is stationary in the strict sense too
- (c) If a Gaussian process is given as input to an LTI system, the output process is also Gaussian
- (d) If two processes which are jointly Gaussian are uncorrelated, then they are statistically dependent

**144.** A PCM system uses a uniform quantizer followed by a 7-bit binary encoder. The bit rate of the system is equal to  $50 \times 10^6$  bits/sec. What is the maximum message signal bandwidth for which the system operates satisfactorily?

- (a) 3.57 MHz
- (b) 4.55 MHz
- (c) 7.55 MHz
- (d) 8.57 MHz

**Directions :**

Each of the next **six (06)** items consists of two statements, one labelled as 'Statement (I)' and the other as 'Statement (II)'. You are to examine these two statements carefully and select the answers to these items using the code given below.

**Code :**

- (a) Both Statement (I) and Statement (II) are individually true and Statement (II) is the correct explanation of Statement (I)
- (b) Both Statement (I) and Statement (II) are individually true but Statement (II) is **not** the correct explanation of Statement (I)
- (c) Statement (I) is true but Statement (II) is false
- (d) Statement (I) is false but Statement (II) is true

**145. Statement (I) :**

Aluminium oxidizes quickly in normal atmospheric conditions and acquires a thin film of oxide  $Al_2O_3$ .

**Statement (II) :**

The high melting point of aluminium oxide coating and the rapidity with which a freely exposed aluminium surface becomes oxidized, make soldering difficult through conventional means.

**146. Statement (I) :**

When the signal is of the form of current, then series input devices are used.

**Statement (II) :**

An ammeter, which is a series device, thus should be designed with a low input impedance so that the current is correctly measured.

**147. Statement (I) :**

If the gain margin is negative, this gives the decibel rise in open-loop gain, which is theoretically permissible without oscillation.

**Statement (II) :**

For a multistage amplifier, if the open-loop gain  $|\beta A|$  is unity when the phase shift is  $180^\circ$ , then the closed-loop amplifier will oscillate.

**148. Statement (I) :**

When negative feedback is applied to the ideal amplifier, the differential input voltage is zero.

**Statement (II) :**

There is no current flow into either input terminal of the ideal op-amp.

**149. Statement (I) :**

When the carrier is generated by a crystal oscillator, the frequency is fixed by the crystal.

**Statement (II) :**

The equivalent circuit of a crystal is an  $L-C-R$  circuit with both series and parallel resonant points.

**150. Statement (I) :**

In FDM transmitter, if the signals which are to be multiplexed will each modulate a separate carrier, then the type of modulation can be AM, SSB, FM or PM.

**Statement (II) :**

In FDM transmitter, the modulator outputs will contain the sidebands of the corresponding signals.



**SPACE FOR ROUGH WORK**

An advertisement banner with a yellow background. On the left, there is a small illustration of a man and a woman. The main text reads "Download FREE UPSC E-BOOKS". To the right of the text is a red circular badge with the word "FREE!" in white. Below the badge is a blue button with the text "CLICK HERE" in white.

Download **FREE** UPSC E-BOOKS  [CLICK HERE](#)

**SPACE FOR ROUGH WORK**

 **Download FREE UPSC E-BOOKS**  [CLICK HERE](#)

**SPACE FOR ROUGH WORK**

An advertisement banner with a yellow background. On the left, there is a small illustration of a man and a woman. The main text reads "Download FREE UPSC E-BOOKS" in bold green letters. To the right of the text is a red circular icon with the word "FREE!" inside. Below the icon is a blue button with the text "CLICK HERE" in white.

**Download FREE UPSC E-BOOKS**  [CLICK HERE](#)

SPACE FOR ROUGH WORK

\*\*\*

An advertisement banner with a yellow background. On the left, there is a small illustration of a man and a woman. To their right, the text 'Download FREE UPSC E-BOOKS' is written in bold, black, sans-serif font. Further right, there is a red circular icon with the word 'FREE!' in white. At the bottom right of the banner, there is a blue rectangular button with the text 'CLICK HERE' in white.