

ENGINEERING SERVICES
EXAMINATION-(M)2017
ELECTRICAL ENGINEERING

ZLX-D-ELT

PAPER—II

Time Allowed : Three Hours

Maximum Marks : 300

QUESTION PAPER SPECIFIC INSTRUCTIONS

**Please read each of the following instructions carefully
before attempting questions**

There are EIGHT questions divided in two Sections.

Candidate has to attempt FIVE questions in all.

Question Nos. 1 and 5 are compulsory and out of the remaining, THREE are to be attempted choosing at least ONE question from each Section.

The number of marks carried by a question/part is indicated against it.

Attempts of questions shall be counted in sequential order. Unless struck off, attempt of a question shall be counted even if attempted partly.

Any page or portion of the page left blank in the QCA Booklet must be clearly struck off.

Assume suitable data, if considered necessary and indicate the same clearly.

Unless otherwise mentioned, symbols and notations carry their usual standard meanings.

Answers must be written in ENGLISH only.

SECTION—A

1. (a) A 10 kW, 400 V, 50 Hz, 4-pole delta-connected squirrel-cage induction motor is excited by 90 V with blocked rotor. The machine consumes 1350 watts and draws 35 A from a.c. mains. The d.c. resistance of stator winding per phase is 0.6 Ω. Assuming effective a.c. resistance per phase to be 1.2 times the d.c. value, compute the starting torque for direct on line starting. Assume $x_2 \ll X_m$. 12
- (b) The per phase parameters of 50 Hz, 100 km long, 3-phase transmission line are $R = 10 \Omega$, $L = 111.7 \text{ mH}$, $C = 0.9954 \mu\text{F}$. The transmission line delivers 20 MW at a power factor of 0.8 lagging and 66 kV to a balanced load. Calculate the sending end voltage, efficiency and regulation using nominal-T representation. 12
- (c) Determine the ripple factor, form factor and utilization factor for a single-phase diode bridge rectifier supplying a purely resistive load. 12
- (d) The unit step response of a unity feedback system is $C(t) = 1 + e^{-4t} - 2e^{-2t}$. Determine—
 - (i) the type and order of the system;
 - (ii) the static error constants of the system;
 - (iii) the open loop poles of the system. 12
- (e) Find the gain v_o / v_i for the ideal OP-AMP shown in the figure below : 12

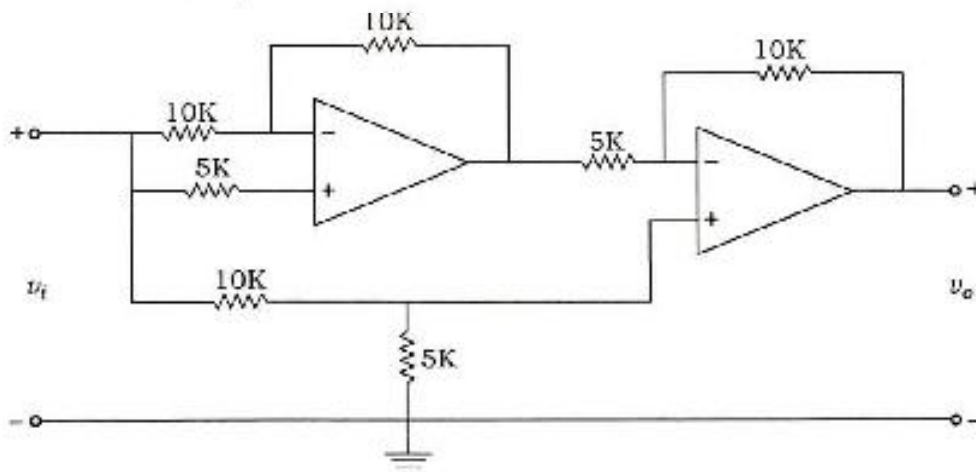

2. (a) A single-phase transformer, having 1000 and 800 number of turns (weighing 80 kg of copper) in primary and secondary windings, is wound over hot-rolled steel core ($\mu_r = 6000$) of uniform cross-sectional area of 80 cm^2 weighing 100 kg. What will be the maximum primary voltage at 50 Hz that can be applied to primary winding which does not force the flux in core to exceed 1.2 T? What is the corresponding exciting current?

If the core of this transformer is replaced by CRGO with maximum flux density capability of 1.6 T, find the saving in core and wire material assuming volume density of both core materials to be approximately same and they have same core flux. Assume mean magnetic path length of 160 cm and $\mu_0 = 4\pi \times 10^{-7}$. 20

(b) The open-loop transfer function of a unity feedback system is given as

$$G(s)H(s) = \frac{4s + a}{s(s^2 + 4s + 9)}$$

Draw the root locus of the system when a varies from 0 to $+\infty$. 20

(c) A set of 10 readings whose individual values are less than $(127)_{10}$ is stored in memory location starting at XX 80 H. Write an assembly language program—

- (i) to check each reading to determine whether it is +ve or -ve;
- (ii) to reject all negative readings;
- (iii) to add all +ve readings;
- (iv) to output this sum to PORT 1, at any time when the sum exceeds eight bits to indicate overflow, otherwise display the sum to PORT 2. 20

3. (a) The self and mutual inductances of two coupled coils of an electromagnetic relay are given by

$$L_1 = \frac{2}{x}, \quad L_2 = \frac{3}{x} \quad \text{and} \quad M = \frac{4}{x}$$

over a certain displacement x in meters. Obtain the expression for force on armature as a function of time, if $i_1 = I_{m1} \sin \omega_1 t$ and $i_2 = I_{m2} \sin \omega_2 t$. Find the magnitude of average force in case (i) $\omega_1 \neq \omega_2$ and (ii) $\omega_1 = \omega_2$. 20

(b) Determine the currents supplied to ring mains shown in the figure below from A to B, when $V_A = V_B$ and $V_B = V_A + 6$ volts : 20

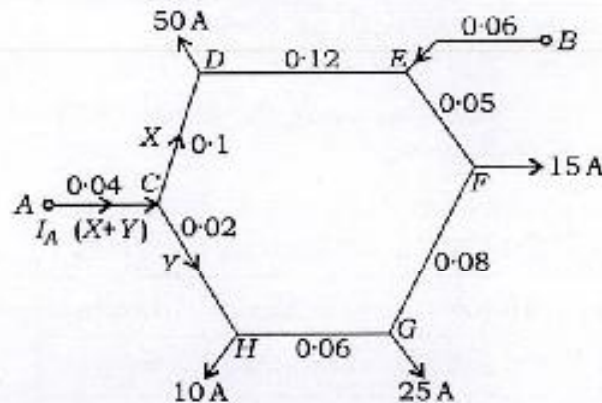

(c) A three-phase, three-pulse, half-wave controlled rectifier is supplying an $R-L$ load, where $L \rightarrow \infty$. A freewheeling diode is also connected across this load. Determine the fundamental displacement factor and distortion factor for this converter as a function of firing angle α and hence determine the power factor of the converter. 20

4. (a) A shunt motor is connected to a constant d.c. voltage source and it drives a constant load torque. Determine the effect of back e.m.f. E_a on speed as a function of flux, when $E_a < V_{t/2}$ and $E_a > V_{t/2}$. 20

(b) A d.c. link has a loop resistance of 40Ω and is connected to transformers giving secondary voltage of 120 kV at each end. The bridge-connected converters operate as follows :

$$\text{Rectifier : } \alpha = 15^\circ, X = 15 \Omega$$

$$\text{Inverter : } \beta = 25^\circ, X = 15 \Omega$$

Calculate the direct current delivered, if the inverter operates on constant ignition angle β control. 20

(c) Write down the trigonometric Fourier series representation of the following signal : 20

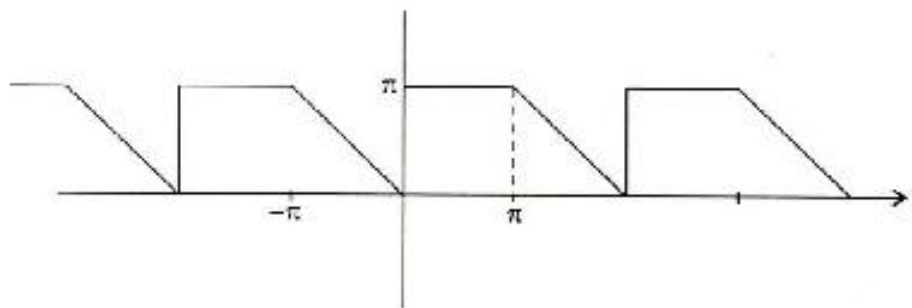

SECTION—B

5. (a) An $11000/440 \text{ V}$, 50 Hz , 800 kVA transformer draws 7.5 kW when excited at normal voltage and frequency with secondary circuit open. At reduced voltage with full-load current, the transformer requires 1.42 kW input, when the secondary is short-circuited. Calculate the all-day efficiency, if the duty cycle of the transformer is as follows : 12

500 kW	0.8 p.f.	6 hours
700 kW	0.9 p.f.	4 hours
300 kW	0.95 p.f.	3 hours
No load	—	11 hours

(b) A single-phase a.c. voltage regulator is made of anti-parallel combination of a thyristor and a diode. This controller is connected to a resistive load of 2Ω from a 220 V , 50 Hz supply. Determine the average and r.m.s. values of thyristor and diode currents for $\alpha = 60^\circ$. 12

(c) Find the phase margin and gain margin of a feedback system with

$$G(s)H(s) = \frac{e^{-0.1s}}{s}$$

Is the feedback system stable?

12

(d) Convert a *D* flip-flop into a *J-K* flip-flop. Use additional logic gates. Draw the implementation.

12

(e) Determine the Laplace transform and the ROC of the signal

$$x(t) = e^{at}u(t-k)$$

12

6. (a) Develop an expression for torque of a 3-phase induction motor from first principles and show that

$$\frac{T_{dm}}{T_{fl}} = \frac{1}{2} \frac{\beta^2 + S_{fl}^2}{\beta S_{fl}}$$

where $\beta = R_2 / X_2$, T_{dm} and T_{fl} are breakdown and full-load torque respectively, S_{fl} is the value of slip at full-load torque.

20

(b) An angle-modulated signal has a carrier

$$V_c = 6 \cos(2\pi 110 \text{ MHz } t)$$

that produces a frequency deviation of 75 kHz due to information signal and a single interfering signal

$$V_n = 0.3 \cos(2\pi 109.985 \text{ MHz } t)$$

Determine the—

- (i) frequency of the demodulated interfering signal;
- (ii) peak phase and frequency deviations due to interfering signal;
- (iii) improvement in the voltage signal-to-noise ratio at the output of the demodulator compared to signal-to-noise ratio at the input.

20

(c) Two sequences are defined as

$$x[n] = \begin{cases} 1, & 0 \leq n \leq 4 \\ 0, & \text{otherwise} \end{cases} \quad \text{and} \quad h[n] = \begin{cases} \alpha^n, & 0 \leq n \leq 6 \\ 0, & \text{otherwise} \end{cases}$$

where α is +ve. Find $x[n] * h[n]$.

20

7. (a) A feedback system is shown in the figure below. Using Nyquist stability criterion, determine—

- (i) the number of closed-loop poles of the system in the right half *s* plane;
- (ii) the closed-loop stability of the system.

20

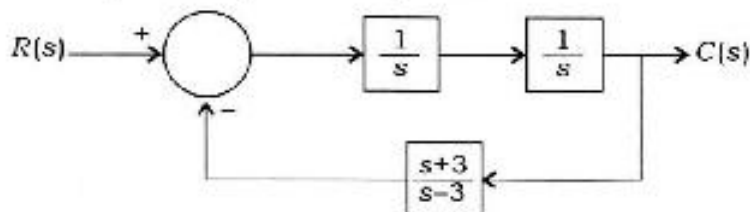

(b) A synchronous generator, capable of developing 500 MW of power, operates at a power angle of 8° . By how much can the input shaft power be increased suddenly without loss of stability? 20

(c) A buck-boost regulator has an input voltage of 6 V. This produces an output voltage of 15 V while supplying an average load current of 0.5 A. The converter is operated at a frequency of 20 kHz. If the inductance and capacitance of the converter are 250 μ H and 440 μ F, then determine the duty cycle, ripple current of inductor and ripple voltage of filter capacitor. Draw the waveforms and derive the relationship used for computing ripple in voltage and current. 20

8. (a) Design a state feedback controller for the linear system described by the following equations :

$$\begin{aligned} 3\dot{x}_1 + 250x_2 &= 500u \\ \dot{x}_2 - 500x_1 + 10x_2 &= 0 \end{aligned}$$

x_1 and x_2 are state variables and u is the input. Design specifications are 20% overshoot and settling time of 5 sec for a step input. Settling time is given for 2% tolerance band. 20

(b) For a simple four-bus system, the line admittances are given below :

Bus code	Admittance
1-2	$2 - j8$
1-3	$1 - j4$
2-3	$0.666 - j2.664$
2-4	$1 - j4$
3-4	$2 - j8$

The schedule of active and reactive power is given below :

Bus	P_i	Q_i	V_i	Remarks
1	—	—	1.04	Slack
2	0.5	0.2	—	PQ
3	0.4	0.3	—	PQ
4	0.3	0.1	—	PQ

Assuming a flat voltage start, determine the voltage at the end of first iteration using Gauss-Seidel method. Take $\alpha = 1.6$ (α is acceleration factor). 20

- (c) A single-phase full-bridge bipolar PWM inverter employs selective harmonic elimination method. The output voltage waveform of the inverter is shown in the figure below. For $\alpha_1 = 23.62^\circ$ and $\alpha_2 = 33.30^\circ$, find the amplitude of 7th, 9th and 11th harmonics :

20

