

MECHANICAL ENGINEERING

Paper – I

Time Allowed : **Three Hours**

Maximum Marks : **200**

Question Paper Specific Instructions

Please read each of the following instructions carefully before attempting questions :

*There are **EIGHT** questions in all, out of which **FIVE** are to be attempted.*

*Questions no. **1** and **5** are **compulsory**. Out of the remaining **SIX** questions, **THREE** are to be attempted selecting at least **ONE** question from each of the two Sections A and B.*

Attempts of questions shall be counted in sequential order. Unless struck off, attempt of a question shall be counted even if attempted partly. Any page or portion of the page left blank in the Question-cum-Answer Booklet must be clearly struck off.

All questions carry equal marks. The number of marks carried by a question/part is indicated against it.

Unless otherwise mentioned, symbols and notations have their usual standard meanings.

Assume suitable data, if necessary and indicate the same clearly.

Neat sketch may be drawn, wherever required.

*Answers must be written in **ENGLISH** only.*



SECTION A

- Q1. (a) The figure below shows a differential gear used in a motor car. The pinion A on the propeller shaft has 12 teeth and gear B has 60 teeth. The shafts S_1 and S_2 form the rear axles to which the road wheels are attached. If the propeller shaft rotates at 1000 rpm and the road wheel attached to axle S_2 has a speed of 210 rpm while taking a left turn, find the speed of road wheel attached to axle S_1 .

8

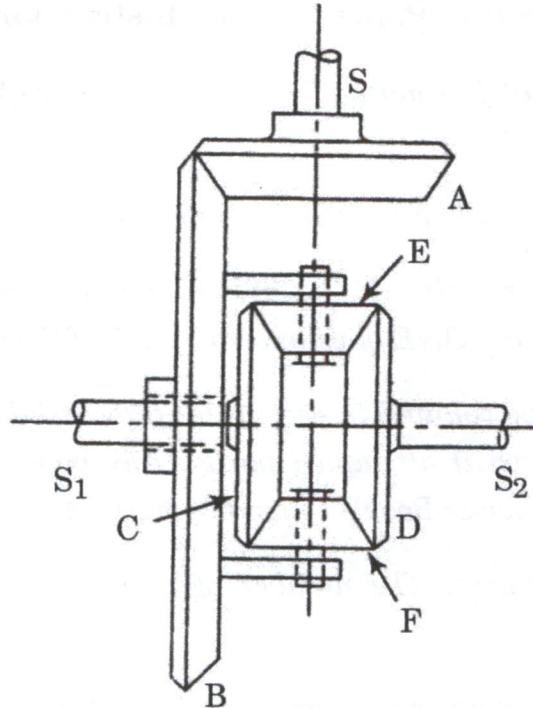

- (b) Knowing that the spring at A is of constant K and that of the bar AB is rigid, determine the critical buckling load (P_{cr}) for the given column.

8

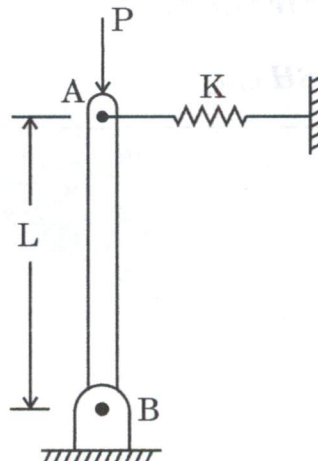

- (c) Sodium is a bcc crystal. Its density is $9.6 \times 10^2 \text{ kg m}^{-3}$ and atomic weight is 23. Calculate the lattice constant for sodium crystal. Consider Avogadro constant as 6.022×10^{26} , and number of atoms present in one unit cell of sodium is 2. 8
- (d) Why is it important for a gear pair to follow the law of gearing ? Explain with sketch. 8
- (e) Determine the maximum torque that can be applied to a hollow circular steel shaft of 100 mm outside diameter and 80 mm inside diameter without exceeding a shearing stress of 60 MPa or a twist of 0.5 deg/m. Use $G = 83 \text{ GPa}$, where G is the modulus of rigidity. 8

- Q2.** (a) An open belt drive is used to connect two parallel shafts 4 m apart. The diameter of the bigger pulley is 1.5 m and that of the smaller pulley is 0.5 m. The mass of the belt is 1 kg/m length. The maximum tension is not to exceed 1600 N. The coefficient of friction is 0.25. The bigger pulley, which is the driver, runs at 250 rpm. Due to slip, the speed of the driven pulley is 725 rpm. Calculate the power transmitted, power lost in friction and the efficiency of the drive. 15
- (b) Draw the shear force and bending moment diagrams for the beam and loading shown, and determine absolute value of (a) the shear, and (b) the bending moment. 15

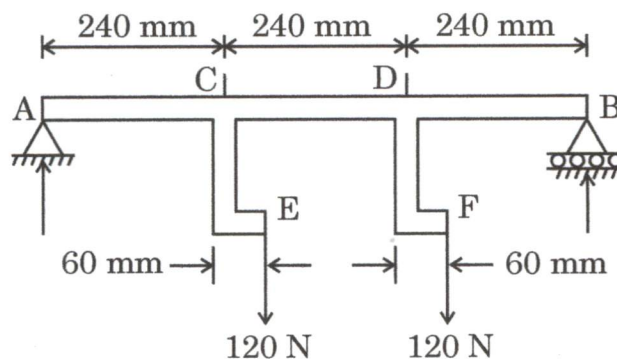

- (c) Enlist the reasons for carrying out case hardening treatment. 10

Q3. (a) (i) Define sensitiveness of a governor. What is hunting in context to a governor ? 5

(ii) A governor of Proell type has each arm 250 mm long. The pivots of upper and lower arms are 25 mm from the axis. The central load acting on the sleeve has a mass of 30 kg and each of the rotating balls has a mass of 4 kg. When the governor sleeve is in mid-position, the extension link of the lower arm is vertical and the radius of the path of rotation of the masses is 175 mm. The vertical height of the governor is 200 mm. If the governor speed is 150 rpm when in mid-position, find the

(1) length of the extension link, and

(2) tension in the upper arm. 10

(b) Using Mohr's circle, for the given state of stress, determine the normal and shear stresses after the element shown has been rotated through (i) 25° clockwise, and (ii) 10° counter clockwise. 15

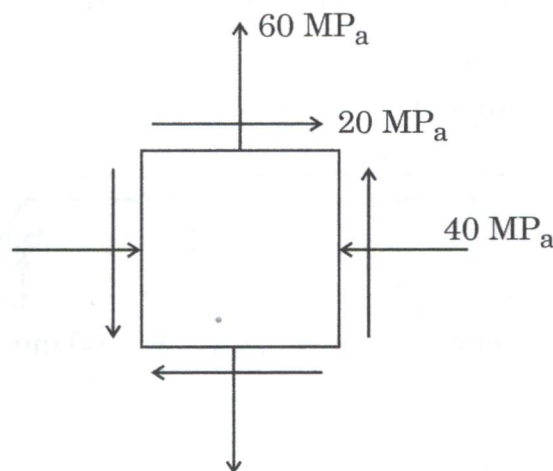

- (c) The turning moment diagram for a petrol engine is drawn to the following scales : Turning moment, 1 mm = 5 N-m;
Crank angle, 1 mm = 1°.

The turning moment diagram repeats itself at every half revolution of the engine and the areas above and below the mean turning moment line taken in order are 295, 685, 40, 340, 960, 270 mm². The rotating masses are equivalent to 36 kg at a radius of gyration of 150 mm. Determine the coefficient of fluctuation of speed when the engine runs at 1800 rpm.

10

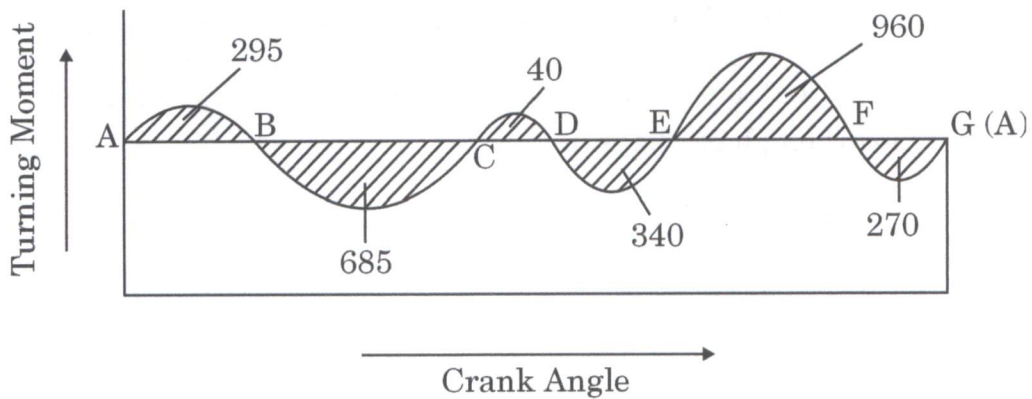

- Q4.** (a) (i) For a single degree freedom system with spring and viscous damper, find out the expression for critical damping constant and damping ratio under free vibration.
- (ii) The figure below shows a single degree freedom system where a massless rigid bar OA is hinged at O and carries a mass m at its other end A. A spring and a viscous damper are attached to the bar vertically as depicted. Determine the critical damping coefficient.

5

10

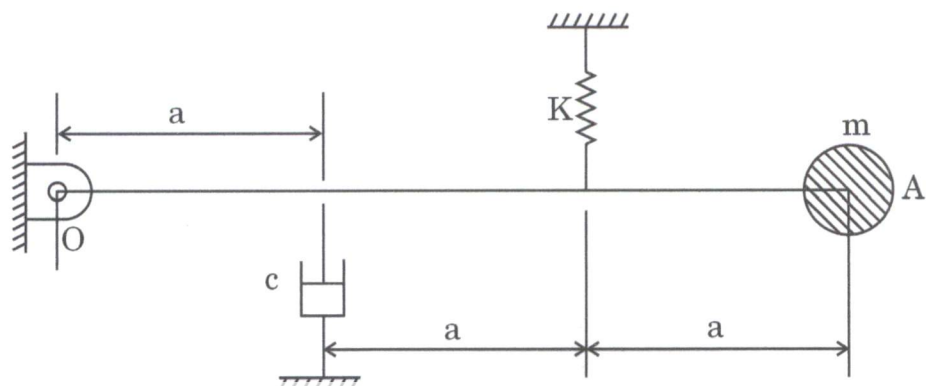

(b) A thick-walled steel cylinder with radii $a = 5$ cm and $b = 10$ cm is subjected to an internal pressure P . The yield stress in tension for the material is 350 MPa. Using a factor of safety of 1.5, determine the maximum working pressure P , according to the following theories of failure :

15

(i) Maximum normal stress theory

(ii) Maximum shear stress theory

(iii) Maximum strain theory

$$E = 207 \times 10^6 \text{ kPa}, \nu = 0.25$$

where E is the Young's modulus, and ν is the Poisson's ratio.

(c) Describe eutectoid and eutectic reactions. Illustrate these reactions on iron-carbon phase diagram.

10



SECTION B

- Q5.** (a) What do you mean by barrel tumbling ? What are the purposes for tumbling employed in surface finish operation ? 8
- (b) Explain the various functions performed by Machine Control Unit (MCU). How does MCU receive the information in NC machine ? 8
- (c) Outline the purposes of Material Requirements Planning (MRP) and explain how an MRP system can achieve these purposes. 8
- (d) A factory manufacturing automobile parts has a separate tool room. The average time between requirements of a tool from tool room by a mechanic is 12 minutes, and this follows the Poisson's distribution. Average service time of the store-keeper is 10 minutes. Determine :
- (i) Average queue length.
- (ii) Average number of mechanics in the system including the one who is being attended to.
- (iii) Mean waiting time of a mechanic.
- (iv) Average waiting time of mechanic who waits. 8
- (e) Illustrate the different data types supported by C programming language. Also state the typical memory requirements for each data type. 8
- Q6.** (a) (i) Write the modified Taylor's tool life equation and explain the role of the machining process parameters on tool life. 5
- (ii) Determine the values of the constant C and index n of Taylor's tool life equation, if the value of tool life is decreased from 40 min to 10 min due to increase in cutting velocity from 80 m/min to 160 m/min in turning a mild steel rod by a coated carbide tool insert under a given condition. 10



- (b) Given the following data for waiting jobs at a work centre. Apply FCFS (first-come-first-serve) and SPT (shortest processing time) sequencing rules and calculate total completion time, average flow time, average number of jobs in the system each day and average job lateness. Also compare the performance of FCFS and SPT rules and give your comments.

15

Waiting job (alphabetically in order of arrival)	P	Q	R	S	T
Processing time (in days)	12	4	16	6	7
Due date (in days from now)	22	14	26	16	17

- (c) Three firms A, B and C manufacture the same product. The selling price for the product per unit is ₹ 15 for all the companies. The fixed costs of the companies are ₹ 1,60,000, ₹ 3,50,000 and ₹ 5,20,000 respectively and the variable cost per unit is ₹ 10, ₹ 7 and ₹ 6. Find :
- Break-even point (physical units) for each company.
 - Profit of the companies if each of them sells 2,00,000 units.
 - Percentage impact on profits of the firms if their sales increase by 20%.

10

- Q7.** (a) (i) In an electrochemical machining process with a pure iron workpiece, a metal removal rate of $5 \text{ cm}^3/\text{min}$ is desired. Determine the current required.

Consider, gram atomic weight, valence at which dissolution takes place, and density of iron as 56 g, 2 and 7.8 g/cm^2 , respectively.

5

- (ii) Discuss the advantages, limitations and applications of electrochemical machining.

10

- (b) Solve the following Linear Programming Problem using Simplex method :

15

$$\text{Maximize } Z = 3X_1 + 2X_2 + 5X_3$$

$$\text{subject to } X_1 + 2X_2 + X_3 \leq 430$$

$$3X_1 + 2X_3 \leq 460$$

$$X_1 + 4X_2 \leq 420$$

$$X_1 \geq 0, X_2 \geq 0, X_3 \geq 0$$

- (c) XYZ Company uses large quantities of a component made up of cast iron. The annual demand of the component is 3000 boxes. The company procures the item from a supplier at the rate of ₹ 600 per box. The company estimates the cost of carrying inventory to be 20% per unit per annum and the cost of ordering as ₹ 1,050 per order. The company works for 260 days in a year. How should the company design an inventory control system for this item ? What would be the overall cost of the plan ? 10

- Q8.** (a) A strip with lead with initial dimensions 24 mm × 24 mm × 150 mm is forged between two flat dies to a final size of 6 mm × 96 mm × 150 mm. If the coefficient of friction between the job and dies is 0.25, determine the maximum forging force. The average yield stress of lead in tension is 7 N/mm². 15

- (b) The monthly demand for units manufactured by ABC Company has been as follows :

Month	Units	Month	Units
May	120	September	100
June	90	October	120
July	120	November	125
August	115	December	130

- (i) Use the exponential smoothing method to forecast the number of units for June to January. The initial forecast for May was 125 units; $\alpha = 0.3$.
- (ii) Calculate the absolute percentage error for each month from June through December and the MAD of forecast error as at the end of December. 15

- (c) Prepare a flowchart to find the square roots of a set of numbers which contains a few negative numbers. 10

